

RECYCLING ABSORBENT CONCEPT

ROSS MOBILE RECYCLING SPILL STATION

TECHNICAL SHEET

1. DESCRIPTIVE

Mobile absorbent station for spills.

The recycling unit allows to separate the saturated absorbent from the absorbent that can be used again. It is designed to be exclusively used with the **Ross Eliminator Absorbent** refills for an instantaneous absorption.

2. PRINCIPLE OF OPERATION



1. Stock & Distribute

The shovel to perfectly collect the absorbent and spread it over the area to be treated.

2. Absorb

Thanks to the provided brush, sweep the concerned area. Be generous and do not pay attention to the quantities as you can recycle the absorbent.

3. Collect & Recycle

Collect thanks to the shovel and then place it on top of the sieve. Shake the sieve over the mobile station so that the non saturated product falls to bottom of the tank. The saturated absorbent staying at the top of the sieve under the form of lumps.

3. TECHNICAL CHARACTERISTICS

Dimension of the Station	L 570 x l 689 x H 1090 (mm)
Empty weight	22,5 kg
Capacity	50L maximum (1 asdvised refill, maximum of 2)
Composition	PEHD rotomoulé
Included	Shovel, Broom, Clips, Sieve

MAIN CHARACTERISTICS

- Absorbs 8 times more than traditional absorbents : clay / sawdust...
- instantaneous absorption
- Any kind of floor: epoxy, paint, concrete...
- Non abrasive
- Silica Free
- Fireproof & waterproof
- Biodegradable and incinerated

ADDITIONAL PRODUCT

- Ross Eliminator Absorbent Refills



RECYCLING ABSORBENT CONCEPT

ROSS MOBILE RECYCLING SPILL STATION

TECHNICAL SHEET

4. DRAWING OF THE STATION

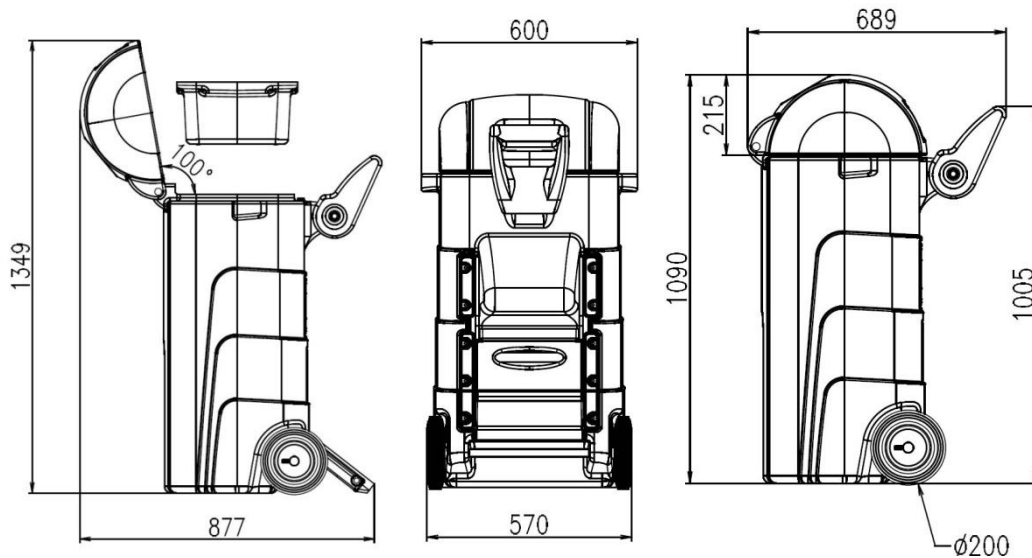

5. 3D VIEWS



Ross Environmental Products Ltd | Cursley Lane, Shenstone, Kidderminster, Worcestershire, DY10 4DX UK

Tél: +(44) 01562 752299 - Fax: +(44) 01562 752400

sales@rossenvironmental.co.uk - www.rossenvironmentalproductsltd.co.uk